



FICPI ExCo & 21st Open Forum

London, 1-7 October 2023



The Protection of Digital Goods

STRENGTHENING THE PRACTICE OF THE INDEPENDENT IP ATTORNEY

www.ficpi.org



euston



21st Open Forum
London, England
4-7 October 2023



Mr Robert Katz
Partner, Banner &
Witcoff Ltd, US



Mr Jing He
Founder &
Managing Partner,
Gen Law, China



Professor David Musker
Professor of International Design
Law at the Centre for Commercial
Law Studies, Queen Mary University
of London, UK



Four General Infringement Frameworks

21st Open Forum
London, England
4-7 October 2023



- Traditional Infringement of Appearance
- Virtual Design Theft
- Digital Design Theft
- Reverse Virtual Design Theft



Traditional Infringement of Appearance

21st Open Forum
London, England
4-7 October 2023



- Design for a traditional physical product AND
- Accused product is a traditional physical product

Original Creation (tangible product)



Unauthorized
Knockoff or Counterfeit





Virtual Design Theft

21st Open Forum
London, England
4-7 October 2023



- Original design for a traditional physical product AND accused product is a digital model of the physical product

Original Creation (tangible product)



Digital
Knockoff or Counterfeit





Digital Design Theft

21st Open Forum
London, England
4-7 October 2023



- Original design for a digital product AND accused product is a digital model too

Original Creation (digital product)



Digital
Knockoff or Counterfeit





Reverse Digital Design Theft

21st Open Forum
London, England
4-7 October 2023



- Original design for a digital product AND accused product is a physical product corresponding to the digital product

Original Creation (digital product)



Tangible
Knockoff or Counterfeit





Potential IP Rights At Issue

21st Open Forum
London, England
4-7 October 2023



- **Design**
- **Copyright**
- **Trademark/Dilution/Trade dress**
- Also:
 - Utility Patents
 - Right of Publicity
 - Right of Privacy
- Will any of them work?
- What are the undetermined issues?



Digital/Virtual - Not Just a Hypothetical

21st Open Forum
London, England
4-7 October 2023



- This is big business
 - Large amounts of money being made and exchanged
 - Infringements are occurring and we are not done seeing them
 - The evolution and the trends of the digital goods market are overwhelming. It's already a gigantic **USD \$950 billion** market considering only consumer apps, enterprise apps, and app-driven IoT technologies, but soon it will be even bigger and dominate the commerce ecosystem
 - The metaverse and NFT projects predicted to be worth **\$50 billion** (360 billion RMB) for the luxury industry by 2030

<https://www.nex.business/the-digital-goods-age>



Where do Digital Designs End Up

21st Open Forum
London, England
4-7 October 2023



- Applications (gaming, web-based and personal inc. VR and AR)
- Development platforms such as Unity and Unreal Engine to create games, animations and CGI movies.
- Modern Virtual Worlds (including DIRECT-TO-AVATAR)
 - Social interaction, role playing games (RPG), the ability to buy and sell virtual products
 - any shared 3D virtual space or "metaverse", including open worlds such as Decentraland and Somnium Space and Minecraft
 - Massive Multiplayer Online Games (like World of Warcraft)
 - Other virtual worlds such as Second Life, Kaneva, IMVU (variety of environments), Our World (younger users), No Mans Sky, Roblox. Sandbox
- 2D Applications (advertisements)



Where do Digital Designs End Up

21st Open Forum
London, England
4-7 October 2023

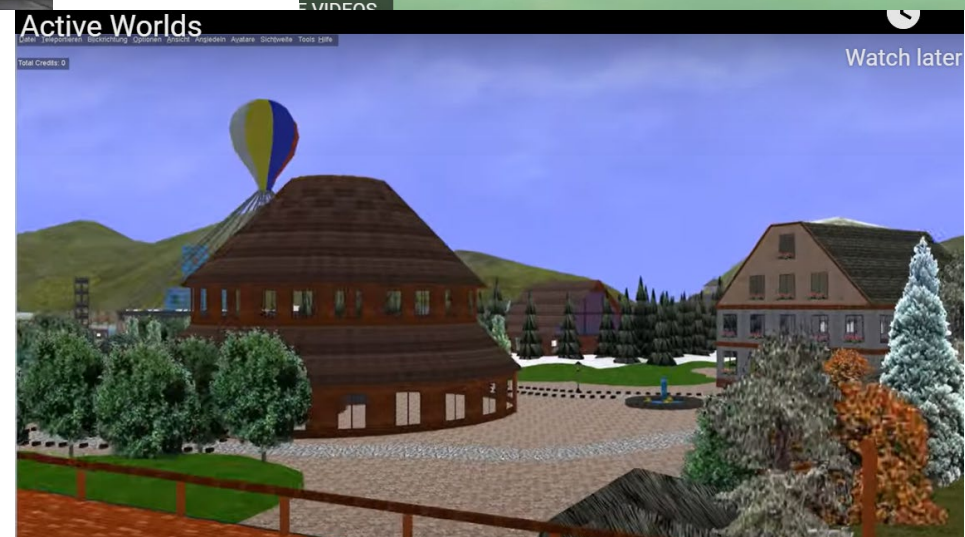
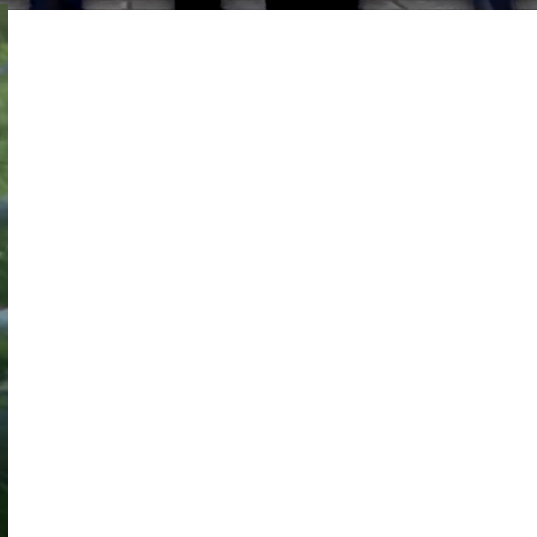



Where do Digital Designs End Up

21st Open Forum
London, England
4-7 October 2023



- Virtual World - The Sandbox
- Play together, create anything, and own virtual LAND. Let's build a whole new world together.
- Customize your avatar
- Buy LAND and turn it into a space where culture and creativity can thrive. Showcase your creations, feature great games, host events, and more. Join the movement and lead the way in shaping the metaverse!

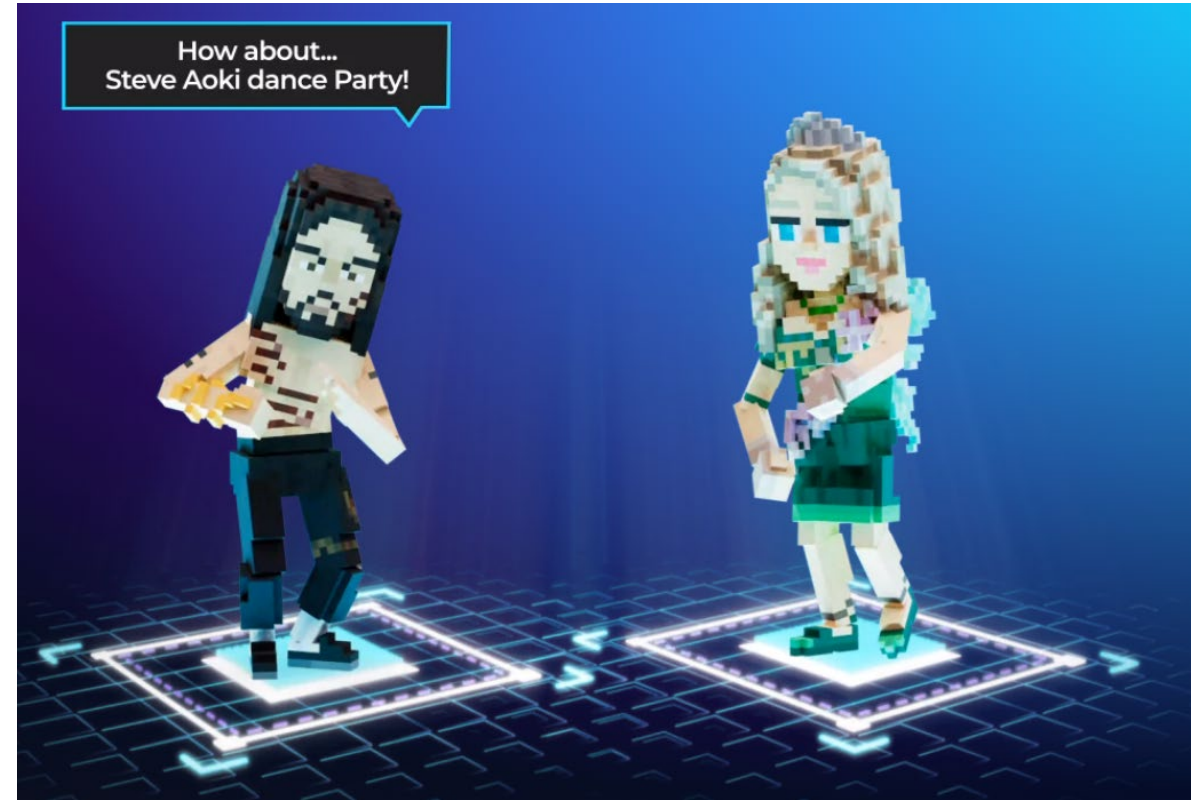

<https://www.sandbox.game/en/>



Where do Digital Designs End Up

21st Open Forum
London, England
4-7 October 2023



Afterworld: The Age of Tomorrow

Balenciaga's fashion video game (2020)



<https://dissrup.com/editorial/digital-fashion-in-the-metaverse>

STRENGTHENING THE PRACTICE OF THE INDEPENDENT IP ATTORNEY

www.ficpi.org



Where do Digital Designs End Up – D2A

21st Open Forum
London, England
4-7 October 2023



- Direct to Avatar. D2A refers to an emerging business model where brands and creators can sell their products directly to a person's virtual avatar (digital identity).
- Younger generations evolve in a fluid digital world in which the boundaries between their physical and online lives have converged. When it comes to fashion, they don't only need physical items to express themselves. "Dressing up their digital self to hang out on digital platforms is real life for them. In this scenario, "Screenwear becomes the new Streetwear."
- A D2A model means:
 - Meeting a demand for fashion that keeps up with digital identities and even digital people
 - Products being sold in social or competitive virtual environments like games or open worlds where consumers project themselves as an avatar
 - Bypassing supply chain management and logistics

<https://disrup.com/editorial/digital-fashion-in-the-metaverse>



Digital Project Trading – Q2 - 2022

21st Open Forum
London, England
4-7 October 2023

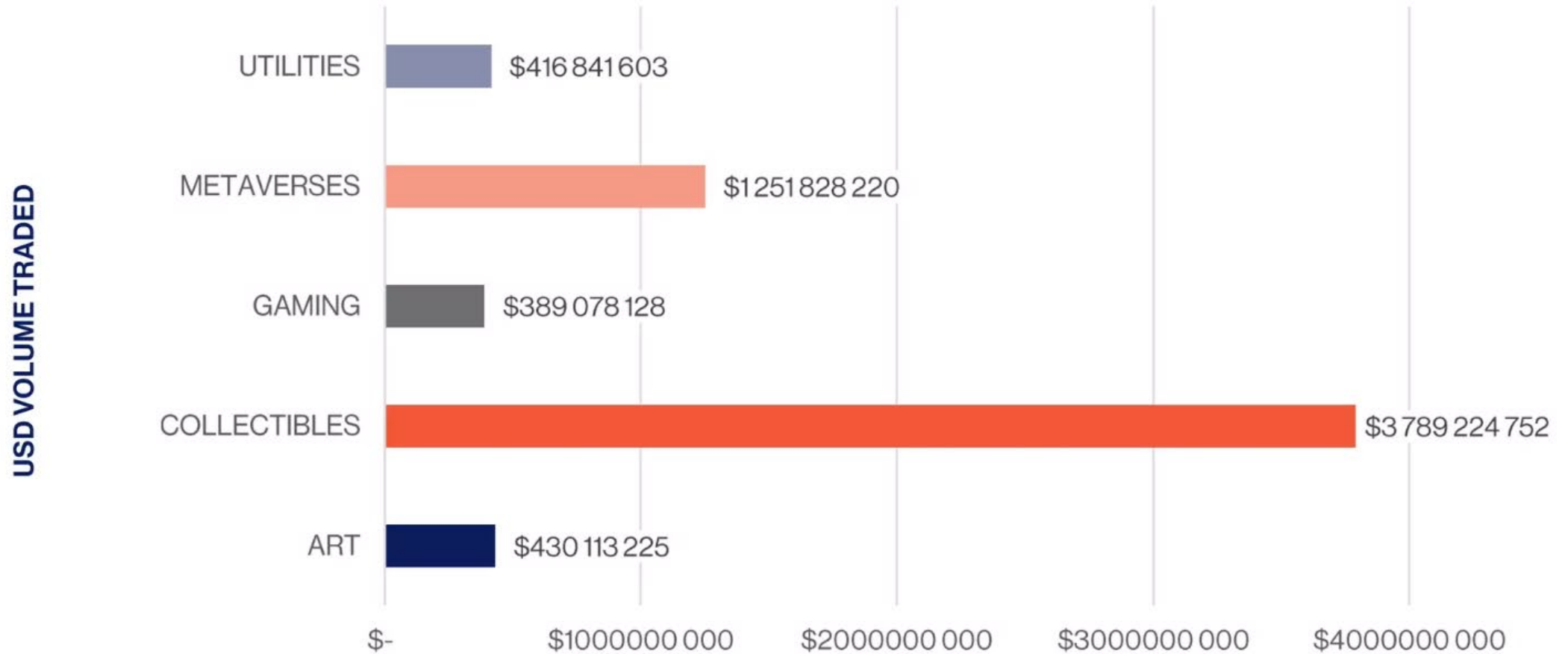

<https://nonfungible.com/market-tracker/>



Digital Project Trading – All Time Sales

21st Open Forum
London, England
4-7 October 2023



1		Bored Ape Yacht Club	\$5,919,365,312.
2		CryptoPunks	\$2,922,706,759.
3		Azuki	\$1,377,730,368.
4		Meebits	\$1,080,906,900.
5		CloneX	\$856,479,631.
6		Moonbirds	\$683,065,960.
7		Doodles	\$649,866,377.

<https://nonfungible.com/market-tracker/>



Digital Project Trading – **This WEEK**

21st Open Forum
London, England
4-7 October 2023



#		Project name	Volume · 7 days ↓	Sales · 7 days
1		Bored Ape Yacht Club	\$4,709,700.93	629
2		CryptoPunks	\$3,200,027.35	50
3		Pudgy Penguins	\$2,020,589.17	982
4		Milady	\$693,444.06	198
5		Azuki	\$580,301.42	230

<https://nonfungible.com/market-tracker/>



Roblox

- Roblox is a massive multiplayer online game aimed at younger users.
- Roblox generated a revenue of \$2.2 billion in 2022.
- Over 56 million people access Roblox daily and 54% of them under the age of 13.
- Roblox paid out \$525 million to creators in 2021
- Roblox most popular world was Adopt Me! with 32.2 billion visits in 2022. Brookhaven had 27.5 billion visits
- Roblox is valued at \$20 billion

<https://www.businessofapps.com/data/roblox-statistics/>





NFT Wearables Market

- The overall size of the NFT wearables market is difficult to establish. In Decentraland alone wearable sales volume totaled \$750,000 in the first half of 2021
- Virtual Sacred Kimono from Decentraland
- Virtual sneaker by digital fashion company RTFKT
- Virtual Shishigami Shoes and Atokirina Full Look by digital fashion company Auroboros

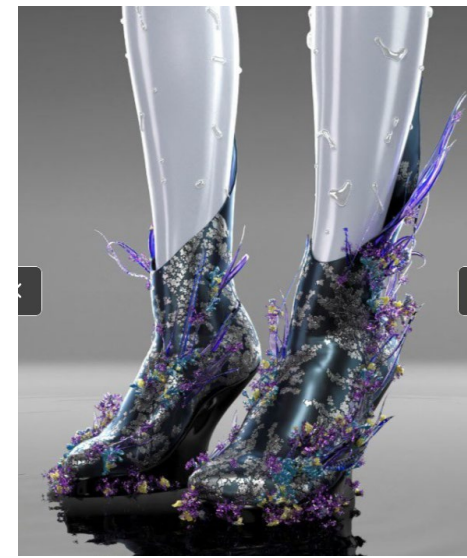
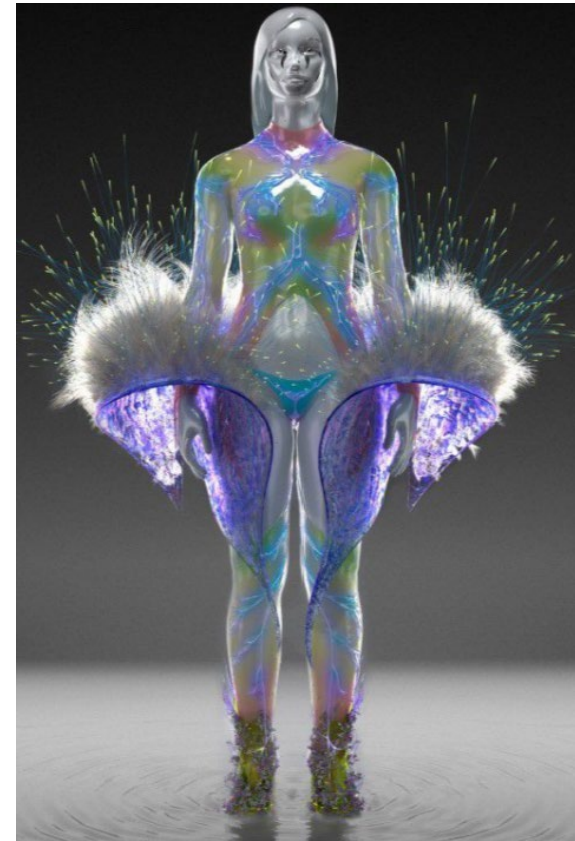



NFT Wearables Market

21st Open Forum
London, England
4-7 October 2023



- Gucci releases first virtual sneaker that can only be worn in digital environments
- Gucci creative director Alessandro Michele has designed a pair of neon-colored, digital-only trainers that people can try on using augmented reality and "wear" in photographs for social media.
- Created in collaboration with AR fashion platform Wanna, the non-physical shoes can be purchased within either company's mobile app for between \$9 and \$12.



<https://www.dezeen.com/2021/03/19/virtual-25-gucci-wanna-digital-sneaker/>



NFT Wearables Market

- Meta Street Market has issued a total of 70,000+ digital fashion collections. With more than 10,000 holders, it has become one of the largest and most influential blockchain fashion project in China.
- We will release different virtual digital sneaker collections with trendy cartoon IPs, like Lilipoki, Qawalli , GuGuMarx , The Universe Life of Talo and more.....
- Expanding into other digital goods

<https://www.metastreetmarket.com/>





CryptoKitties

21st Open Forum
London, England
4-7 October 2023



- CryptoKitties is a game centered around breedable, collectible, digital creatures. Each cat is one-of-a-kind and 100% owned by you; it cannot be replicated, taken away, or destroyed.
- According to some estimates, the game had 1.5 million users who were responsible for \$40 million worth of transactions.
- Individual cryptokitties have sold for more than \$300,000 a piece. As of June 2019, the average sale price for a cryptokitty was \$65.76.
- Experienced players look for rarity, utility, and appearance in a Kitty.
- The success of Cryptokitties has led to a surge of crypto collectibles in the market.

<https://www.cryptokitties.co/>





CryptoPunks



- CryptoPunks: 10,000 unique collectible characters with proof of ownership stored on the Ethereum blockchain. The project that inspired the modern CryptoArt movement. No two punks are alike.
- Originally, they were free. But now they must be purchased from someone on the Ethereum marketplace contract. Via the market, you can buy, bid on, and offer punks for sale.
- Current lowest price punk available - 20.6 ETH (\$59K USD)
- Total value of all sales (lifetime) - about \$3B USD



#7804

4.2KΞ (\$7.57M)

Mar 11, 2021

<https://www.larvalabs.com/cryptopunks>



Solare

- A fantasy soccer game where you can trade official blockchain player cards. Also has NBA and MLB games.
- **Rare** Player Cards are issued at 100 editions per season.
- **Unique** Player Cards are issued once per season.
- Buy, sell, and trade digital player cards on Sorare's live Marketplace - which features thousands of players - week over week and season over season. Improve your lineups by adding top performers for an immediate roster boost, or next-generation stars for long-term production.
- Kylian Mbappé
 - First sale price: 2.3 Eth = \$3,840 USD
 - Last sale price: 9 Eth = **\$15,00 USD**
- Cesinha
 - Only sale price: 2.3 Eth = **\$39,811 USD**
- Isaiah Livers
 - price: .14 Eth = **\$195.11** £ (\$234 USD)
- Trea Turner
 - price: .0237 Eth = **32.50** £ (\$40 USD)

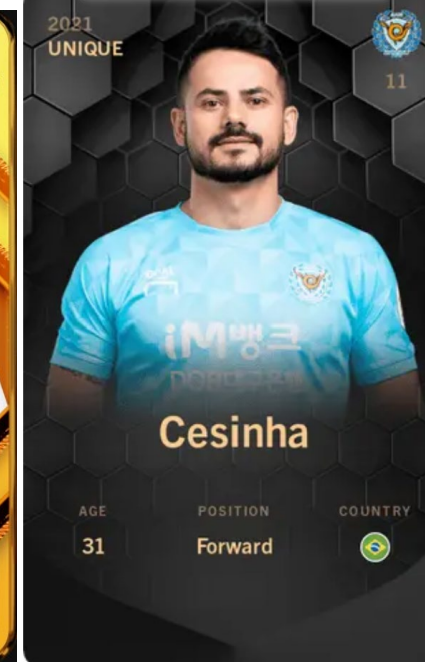
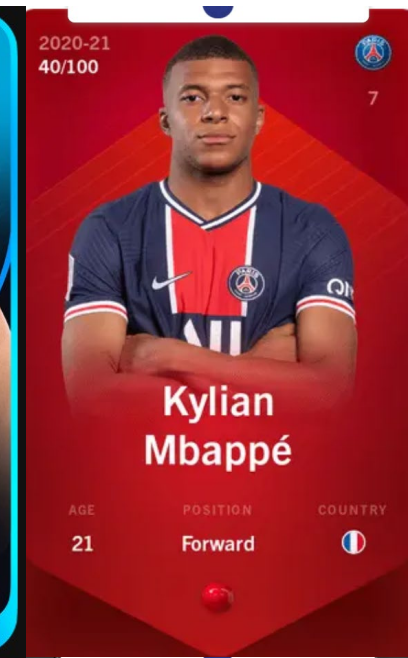

<https://nonfungible.com/market/history/sorare> AND <https://sorare.com/>



SuperRare

- SuperRare makes it easy to create, sell, and collect rare digital art by artists around the world. Our smart contract platform allows artists to release limited-edition digital artwork tracked on the blockchain, making the art rare, verified and collectible. Artists are provided with a new revenue stream, helping to fund new creative projects.
- Destination Hexagonia by DonDiablo (618 ETH = **\$1.3M**)
- Money Factory by MrMisang (206 ETH = **\$520K**)



<https://nonfungible.com/market/history/superrare> AND <https://superrare.co>



Beeple Digital Collage (2021)

21st Open Forum
London, England
4-7 October 2023



- Mike Winkelmann/Beeple created a digital collage titled "Everydays: The First 5,000 Days," - 5,000 images created by the artist over a period of as many days in his life.
- Sold for **\$69M USD** at Christies Auction
- Digital art called Nonfungible Token or NFT, which is built on the blockchain framework.

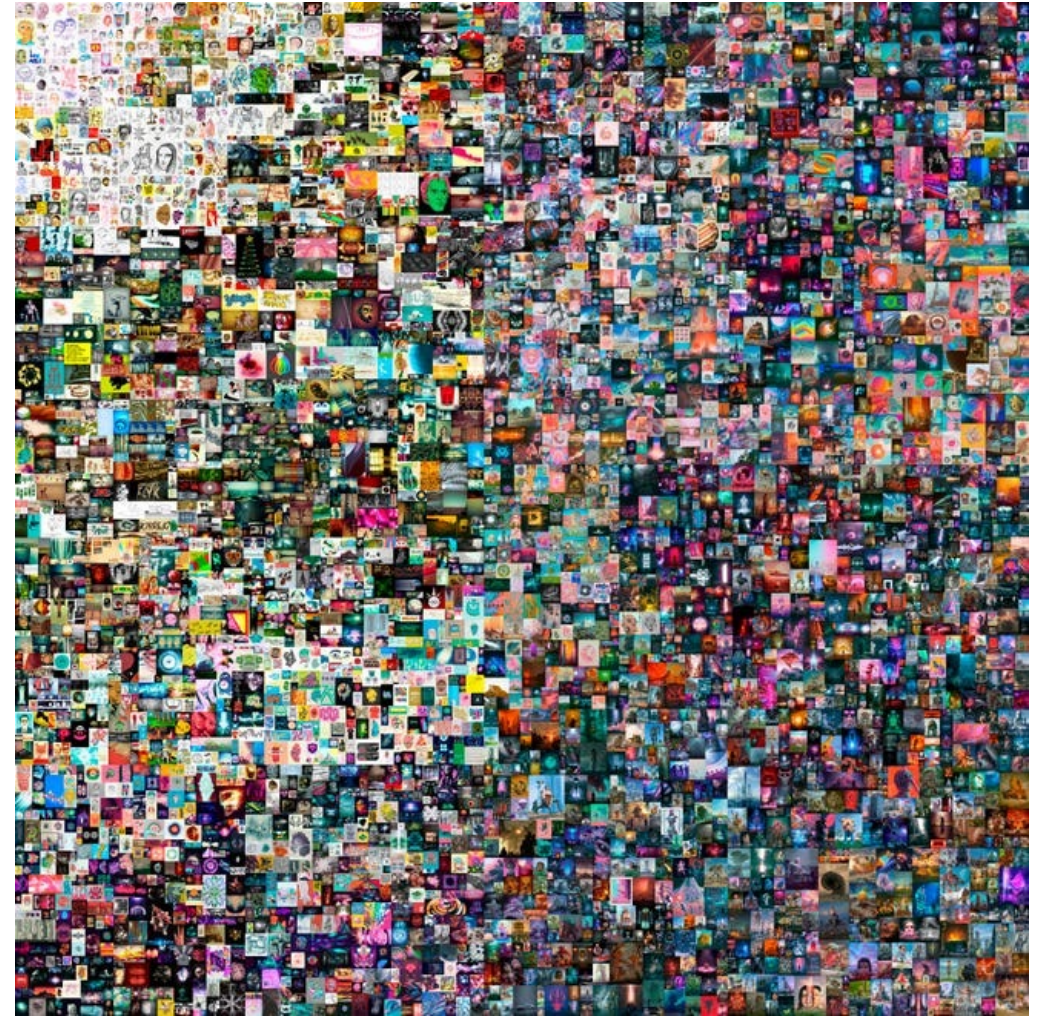

<https://www.fdlreporter.com/story/news/2021/03/15/beeple-artist-69-3-millions-sale-hails-north-fond-du-lac/4699856001/>



Reisinger Digital Furniture (2021)

21st Open Forum
London, England
4-7 October 2023



- Andrés Reisinger sells collection of 10 "impossible" virtual furniture pieces for **\$450,000 USD** at auction
 - most expensive non-existent item fetching almost \$70,000.



Matsumoto Bench



Complicated Drawer

<https://www.dezeen.com/2021/02/23/andres-reisinger-the-shipping-digital-furniture-auction/>



Virtual House (2021)

21st Open Forum
London, England
4-7 October 2023



- The first NFT digital house in the world" sold for over **\$500,000 USD**
- Named Mars House, the colourful virtual home designed by Krista Kim was sold on NFT marketplace SuperRare for 288 Ether (\$512,000), a cryptocurrency similar to Bitcoin.

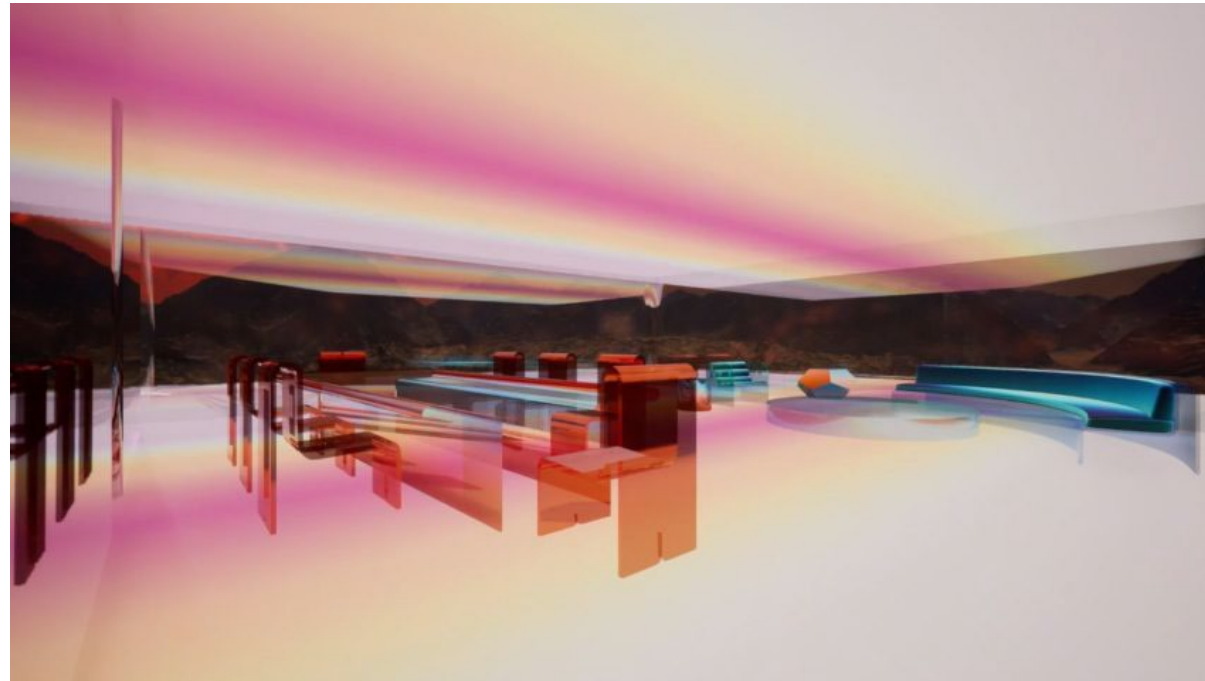

<https://www.dezeen.com/2021/03/27/this-week-virtual-house-sold-mars-nft/>



Rtfkt/Fewocious Digital Shoes (2021)

21st Open Forum
London, England
4-7 October 2023



- A trio of sneakers that looked a bit like doodled-on NIKE Air Force Ones—a collaboration between design studio Rtfkt and Fewocious, an 18-year-old digital artist living in Seattle.
- Listed respectively at \$3,000, \$5,000 and \$10,000 the three chaotic designs, each slightly different, were sold during one seven-minute period.
- In total, 621 pairs were purchased, netting the equivalent of \$3.1 million.



<https://www.wsj.com/articles/nfts-and-fashion-collectors-pay-big-money-for-virtual-sneakers-11615829266?page=1>



Gucci Dionysus bag

- A digital Gucci Dionysus bag just sold for \$4,115 which is more than the \$3,400 price tag of its physical counterpart in a store.
- A digital-only asset that exists exclusively in and with no value outside of the Roblox metaverse.



<https://www.linkedin.com/pulse/direct-avatar-economy-metaverse-camila-straschnoy/>



Virtual Design Theft – Digital Use and 3D Printing

21st Open Forum
London, England
4-7 October 2023



Original Creation (tangible product)



Digital
Knockoff or
Counterfeit



Ferrari F50

by KG12, published May 14, 2015

Thingiview

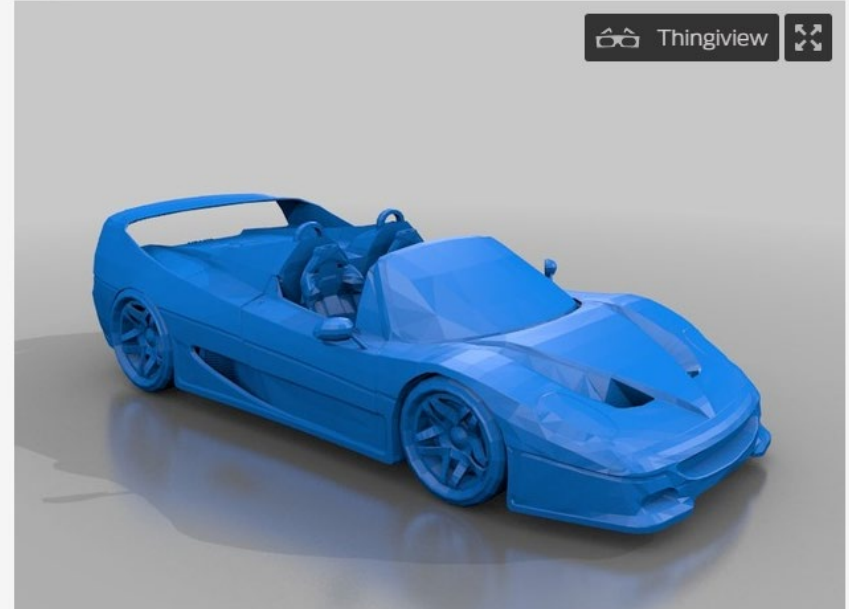



Virtual Design Theft – Digital Use and 3D Printing

21st Open Forum
London, England
4-7 October 2023



Original Creation (tangible product)



Digital
Knockoff or
Counterfeit

<https://www.turbosquid.com/Search/Index.cfm?keyword=herman+miller>

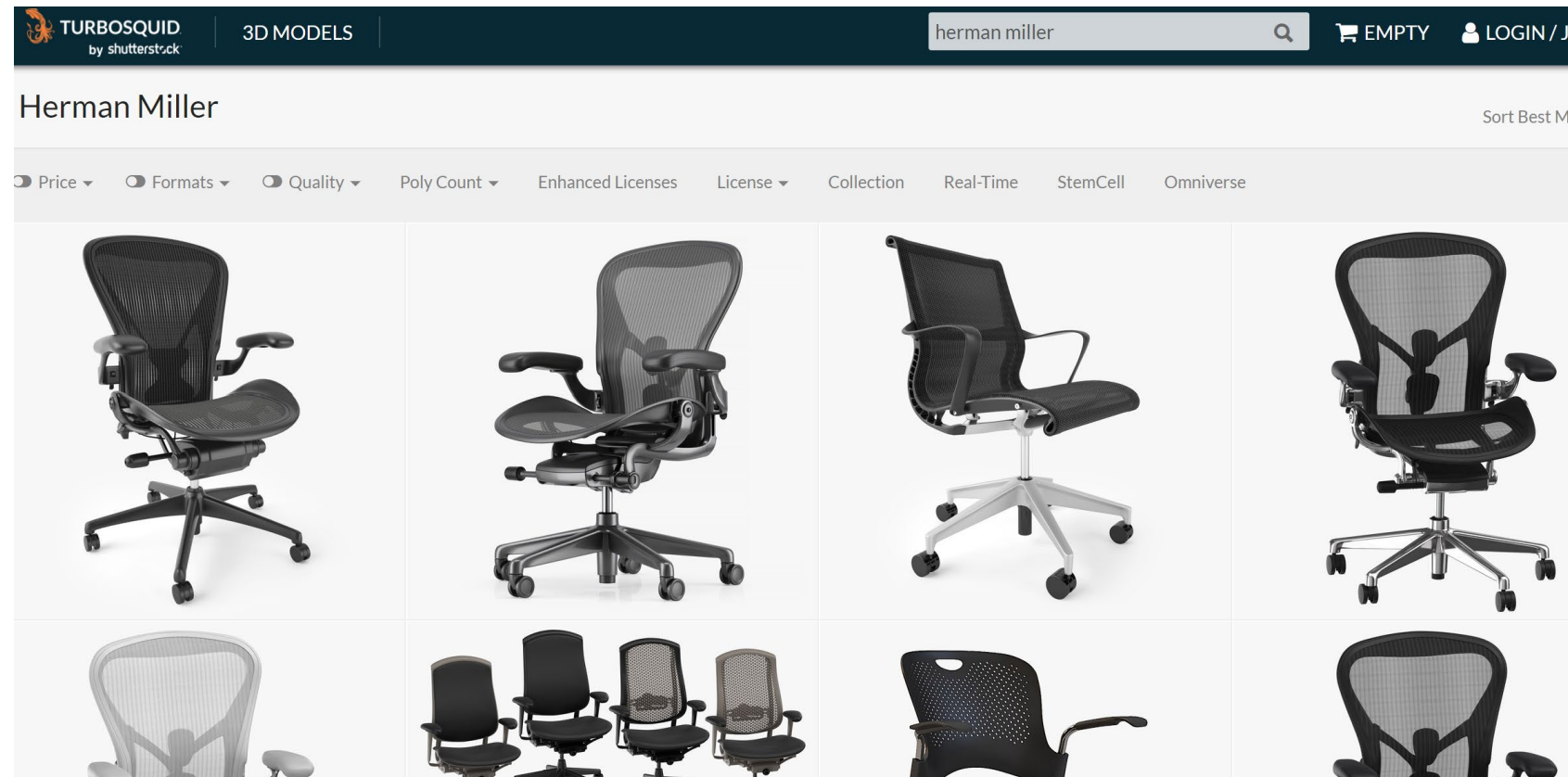



Crossover Worlds

21st Open Forum
London, England
4-7 October 2023



- *Things are starting to blur*
- *Digital is crossing into physical products*
- *Digital is crossing into real life experiences*
- *Digital is crossing into other digital*
- *Digital is property*



Crossover Worlds

- *Reisinger Digital Furniture (2021)*
- Hortenza Chair (digital design went viral in 2018)
- Led designer to create actual retail product in 2019
- First real version of the Hortenzia chair is on display at the Montoya gallery in Barcelona.
- The upholstery consists of 20,000 fabric petals
- Now for sale for over \$27K USD

<https://www.dezeen.com/2021/02/23/andres-reisinger-the-shipping-digital-furniture-auction/>

<https://www.dezeen.com/2019/12/13/andres-reisinger-hortenzia-chair-design/>

https://www.1stdibs.com/furniture/seating/chairs/modern-hortenzia-side-occasional-chair-fuzzy-powder-pink-fabric/id-f_19691632/



Virtual Hortenzia chair.

Tangible Hortenzia chair.

Modern Hortenzia
Side or Occasional
Chair in Fuzzy Powder
Pink Fabric

\$27,298.08

Estimated Production Time: 11-12 weeks





Crossover Worlds

- *Reisinger Digital Furniture (2021)*
- Complicated Sofa first digital
- Now for sale \$12K USD

Complicated long
tangled snake Sofa in
Silver by Reisinger
Andres

\$12,094.85 per item

Estimated Production Time: 9-10 weeks

<https://www.dezeen.com/2021/02/23/andres-reisinger-the-shipping-digital-furniture-auction/>
https://www.1stdibs.com/furniture/seating/armchairs/complicated-long-tangled-snake-sofa-silver-reisinger-andres/id-f_15679881/



Virtual Complicated Sofa

Tangible Complicated Sofa





Crossover Worlds

- RTFKT x Jeff Staple Meta-Pigeon
- NFT sneaker drops can be redeemed for physical copies of their digital counterparts. Uses a technique where the sneaker looks almost one to one with the 3D look of the NFT



<https://www.nicekicks.com/jeff-staple-rtfkt-studios-meta-pigeon-nft-physical-sneakers/>



Crossover Worlds

- Forging Events
- Can trade in NFTs for real shoes
- Custom sneakers inspired by the Japanese artist's colorful motifs have previously made rounds across the internet, but the upcoming collection brings them to official sneaker form for the first time. Two different Nike Air Force 1 styles will be available – “Murakami Drip” and “Murakami DNA” – as highly-limited digital collectibles (4,349 copies in total between both options). Owners of the non-fungible tokens (NFT) will be able to forge their virtual collectible for a physical copy of the Murakami Air Force 1s.
- At the time of this writing, pricing on the OpenSea platform for the digital collectibles is as follows: 0.51 ETH (approximately \$960 USD) for the “Murakami Drip”; 4.99 ETH (approx. \$9,400 USD) for the “Murakami DNA.”
- Both styles feature a standard Air Force 1 sole unit, although the uppers are covered in multi-colored patterns by Murakami. Each collectible also includes RTFKT bolt and Nike swoosh logos.



<https://sneakernews.com/2023/04/10/murakami-rtfkt-nike-air-force-1-april-2023/>



Crossover Worlds - Spirits

- Luxury Spirits Labels Are Unbottling The NFT Market
- Johnnie Walker (Diageo) issued 75 Blue Label Ghost bottles, to the even rarer Master of Flavour whiskies aged at least 48 years. The latter also came with exclusive tastings and a \$35K price tag. Now going for \$65K
- Hennessy launched a cultural membership ... as proof of membership to exclusive events and experiences, but most importantly access to a community.
- NFT platform BlockBar
 - The LVMH-owned Cognac brand Hennessy released an NFT of the first and last bottles (1 and 250, respectively) of Hennessy 8, a rare, limited-edition series. The NFT was sold for a staggering \$221,000.

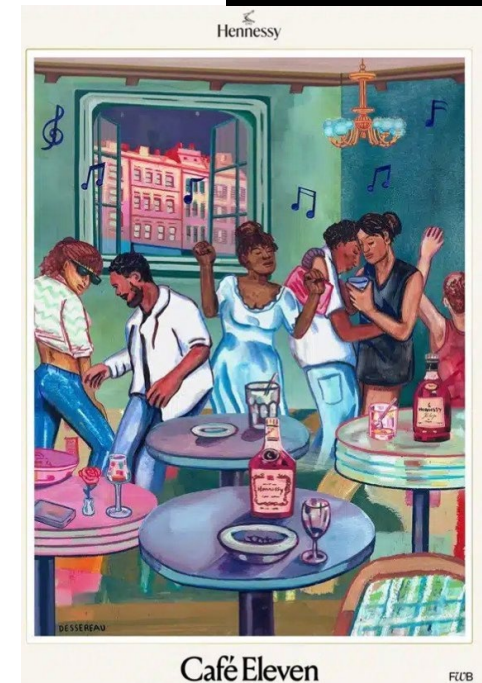

<https://jingdaily.com/luxury-spirits-nft-johnnie-walker-hennessy/> and <https://blockbar.com/>



Crossover Worlds - Spirits

- 1800 is the latest spirits producer to get into the cryptocurrency game with the release of an NFT corresponding to a bespoke 1800 Colección Tequila decanter.
- The tequila NFT and decanter have gone up for auction on BlockBar, a new marketplace which specializes in NFTs tied to physical bottles of spirits and wine. Bidding started at \$25,000. It sold out.
- The decanter, designed by surrealist Mexican artist Leonora Carrington, houses a bottle of 1800 Colección Extra Añejo. Prior to her passing in 2011, Carrington made 15 of these ornate silver monoliths. This will be the first one ever sold to market.
- The buyer of the tequila NFT will be entitled to a trip to Jalisco, Mexico for a private tasting of 1800 Colección Tequila, along with a guided tour of Leonora Carrington's private art collection.

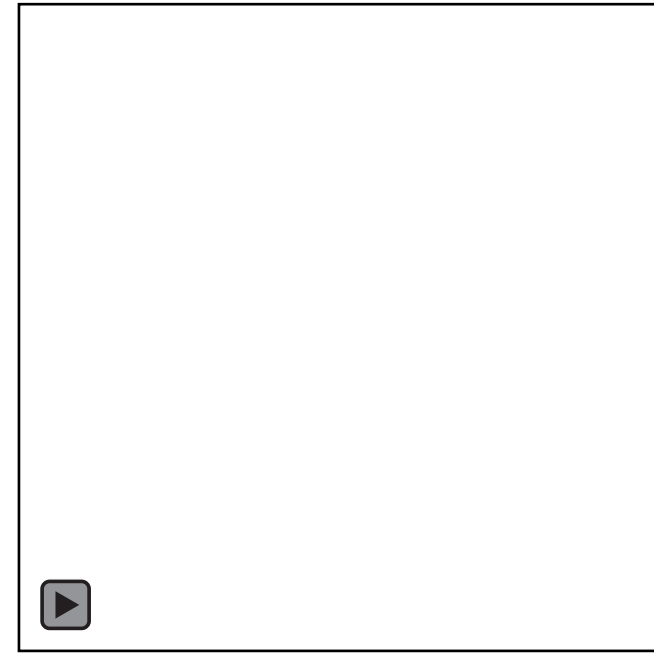

<https://jingdaily.com/luxury-spirits-nft-johnnie-walker-hennessy/> and <https://blockbar.com/> and <https://tequilaraiders.com/tequila/1800-tequila-nft/>



Crossover Worlds - Spirits

- Patrón Tequila has partnered with non-fungible token marketplace BlockBar to launch a bottle of limited-edition Patrón Chairman's Reserve.
- The first time this exclusive aged tequila has been released to the public. Only 150 individually numbered bottles will be available.
- The NFT started bidding at 1.5 ETH (then worth about \$5,000 USD)
- The buyer may choose to redeem the physical product and have it delivered from BlockBar's secure storage facility, safely trade its NFT version within the BlockBar.com marketplace, keep it in their virtual bar or gift it through BlockBar's new gifting system.

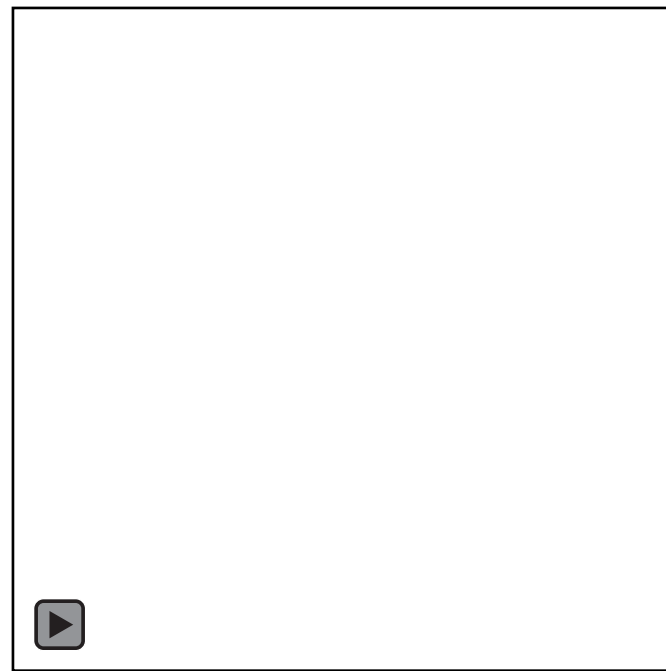

<https://jingdaily.com/luxury-spirits-nft-johnnie-walker-hennessy/> and <https://blockbar.com/> and <https://whiskeyraiders.com/article/patron-tequila-nft-chairmans-reserve/>



Crossover Worlds - Spirits

21st Open Forum
London, England
4-7 October 2023



- Appeal of NFTs is clear:

- Taps into a loyal audience with disposable income
- Create a permanent link between company and customer, etched onto the blockchain
- Data they derive allows us the opportunity to engage and educate influential consumers with invitations to exclusive private tastings, brand home visits, or hospitality at key events
- Builds more trust while tackling counterfeits
- Luxury spirits are often seen as the preserve of older, more affluent collectors. But NFTs could be set to change that, as a cohort of newly rich, tech-and-crypto-savvy buyers grows accustomed to seeing digital goods as valuable — sometimes even more valuable — than physical ones

- Even in the Metaverse

- Recently, Patrón took things a step further with a series of pop-up shops in the metaverse. Users were invited to a “Patrón Summer Metaverse Quest” in which they could purchase virtual Patrón merch and even buy virtual cocktails including a Silver & Soda, an Añejo Highball and a Perfect Paloma.

<https://jingdaily.com/luxury-spirits-nft-johnnie-walker-hennessy/> and
<https://tequilaraiders.com/tequila/1800-tequila-nft/>



NFT-Backed Goods

21st Open Forum
London, England
4-7 October 2023



- NFT – a digital token, managed on a blockchain (like cryptocurrency)
- Can be used to (i) authenticate a product, by (ii) tracking ownership.
- Underlying goods could be:
 - Virtual goods (e.g. pictures), or
 - Physical goods (e.g. sneakers).
- Potentially creating limited editions, avoiding counterfeits.



US IP Considerations



Design Patent Case

- *P.S. PRODUCTS v. ACTIVISION BLIZZARD* -- US DC ARKANSAS
- Design patent to actual brass knuckles – stun gun
- Video game maker made virtual weapon for game characters
 - Used in *Call of Duty, Black Ops II*
 - Looked nothing like the design patent
 - Activision Blizzard did not make or sell physical Galvaknuckles.
- Dismissed for failure to state a claim (based on principles from *Gorham test*)
 - "[n]o reasonable person would purchase defendants' video game believing that they were purchasing plaintiffs' stun gun"

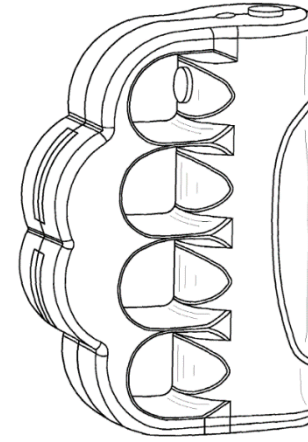

P.S. Products' D561,294



Activision Blizzard's Galvaknuckles



Design/TM Case

- *BMW v. Turbosquid*
- BMW enforced 6 Design patents + many trademarks
- BMW uses/licenses IP rights on miniatures, 3D virtual models for computer games, toys and a variety of other commercial applications.
- Turbosquid sells digital models
- Accuses Turbosquid of trademark, trade dress and design patent infringement (and unfair completion, unjust enrichment)
- Filed 5/3/2016 and settled shortly thereafter

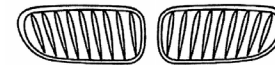
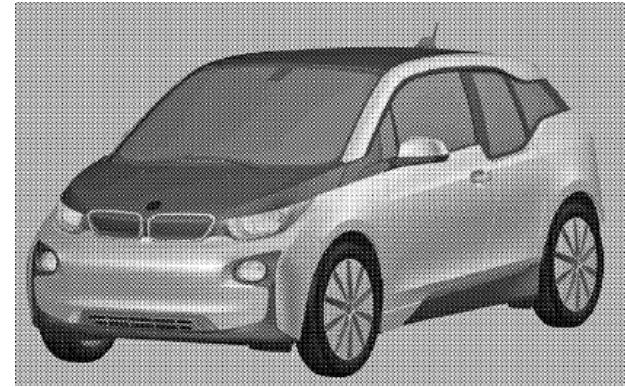

BWM Rights



Turbosquid



Design/TM Case

- *Taser Int'l v. Linden Research et al*
- Taser makes and sells weapons that deliver a jolt of electricity – usually for police departments
- Taser sued for
 - Trade dress and marks “TASER” for non lethal firearms
 - US Des. Pat. Nos. D504,489 & D508,277 (“Gun”) and
 - more
- Virtualtrade sold virtual weaponry using the name TASER to use in computer animations provided by Linden (Second Life)
- Defendants also sell “adult-only explicit scenes” and “unlawful drug materials”
- Settled shortly after complaint

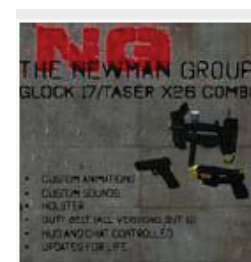
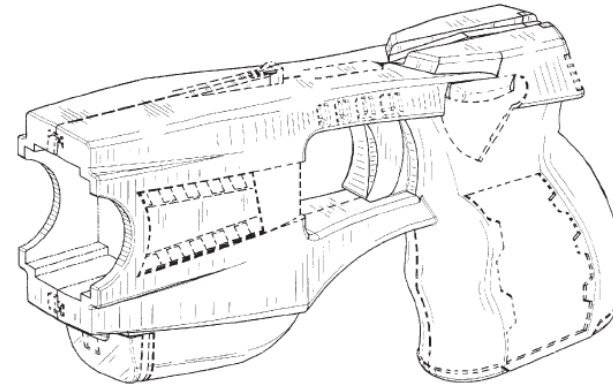
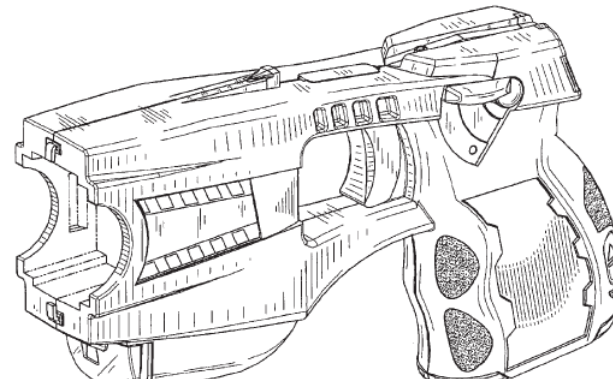

Click to view more items L\$1200
 What are Tasers? Tasers are hand-held weapons that deliver a jolt of electricity through a pair of wires propelled by compressed air from up to 10...
[More...](#)



VGS Long Range Taser Gun L\$895
 Long range authentic taser gun stuns and immobilizes victims from 15 to 20 meters away. Custom animations, sound effects and innovative scripting. ...
[More...](#)



Design Patent Case



- *In re SurgiSil*, 14 F.4th 1380 (Fed. Cir. 2021)
- “In *Curver*, we held that the claim at issue was limited to the particular article of manufacture identified in the claim.”
- As such, the claim is limited to lip implants and does not cover other articles of manufacture. There is no dispute that Blick discloses an art tool rather than a lip implant. The Board's anticipation finding therefore rests on an erroneous interpretation of the claim's scope.”



Blick® “Stump” Art Tool

Prior Art Design

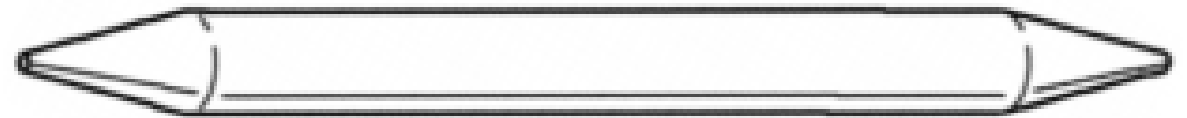

“Lip Implant”

Claimed Design



Design Patent

- *US D975,725 – Assignee NIKE*
- Display Screen with Virtual Three-Dimensional Shoe or Display System with Virtual Three-Dimensional Shoe





Crossover Worlds

21st Open Forum
London, England
4-7 October 2023



- RTFKT X NIKE Dunk Genesis Cryptokicks sneakers
- Cryptokicks limited to 19,000 pairs. Sold as NFTs that can then redeemed for their physical counterparts, a process RTFKT dubs “Forging.”



<https://sneakernews.com/2022/12/07/nike-cryptokicks-irl-release-date/>



Design Patent

- *US D1,000,478 – Assignee NIKE*
- Display Screen with Virtual Three-Dimensional Shoe or Display System with Virtual Three-Dimensional Shoe

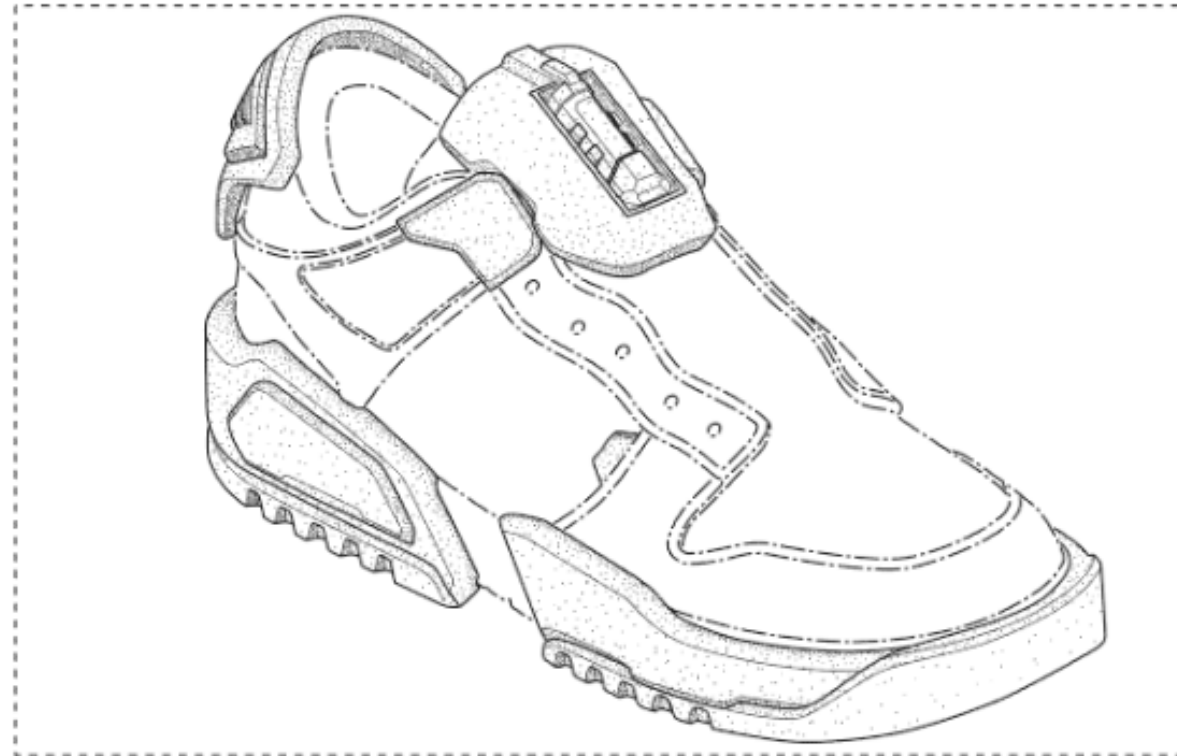



IP Considerations – Design Patents



- Recent cases - – *title (i.e., the claim) of the design matters for scope*
- Is a digital model of a tangible good the same design as the identical tangible good???
- Opportunity to argue law?
 - Section 171: design **for** an article of manufacture
- USPTO and liberal alternative titles
- Recent feedback USPTO doesn't seem positive for helping innovation in the digital worlds
 - Looking more for tie-in to being computer related
 - BUT PTAB seems to disagree
- You need to get a design patent to have an enforceable right



TM Case

- ***Hermès International v. Rothschild***
- Rothschild created “MetaBirkins,” a collection of digital images depicting faux-fur-covered Birkin handbags (100 NFTs). Rothschild then used NFTs to sell the MetaBirkins.
- The NFTs have sold on four different NFT platforms, and though the value of cryptocurrency continues to fluctuate, some of the NFTs in this collection have been sold for prices comparable to real-world, physical Birkin handbags.



An Hermès Birkin Bag



A Metabirkin Sold via NFT





TM Case

- *Hermès International v. Rothschild*
- Suit was for trademark infringement, dilution, cybersquatting, and false designation of origin
- Motion to dismiss by Rothschild denied
- Jury found for Hermès that Mason Rothschild had indeed infringed the trademarked Birkin bag with his MetaBirkins project and assessed \$133K in damages (for minting 100 unique NFTs)



RN: 2991927	RN: 3936105
	



IP Considerations – TM/Trade Dress



- Product Configurations/Trade Dress
 - Non-functional
 - Acquired distinctiveness/secondary meaning
 - Source identifier versus mere design
- Digital Goods
 - Is a digital good a “product”
 - Same or different standards as above?
- Likelihood of confusion
 - Multi-factor test
 - What about the class of goods?
- Defenses - fair use and first amendment
- Dilution (famous marks)



Federal TM Filings



- Digital only and digital first marks are being filed
- From 2021-2022, there was a significant rise in the number of trademark applications to protect goods and/or services relating to NFTs or goods and/or services in the virtual world. That number is on the decline.
- The number of applications has slowed and is currently on a decline
- USPTO has guidelines and the Acceptable Goods and Services Manual updated several times in 2022-2023 to address these filings
- ***See also USPTO Handout***
 - → <https://www.uspto.gov/sites/default/files/documents/TM-Newer-Technologies-handout.pdf>



Federal TM Filings – What Classes



- Primarily seeking protection in Classes 9, 35, 41, and 42
- Sometimes seeking protection in the classes of the applicant’s primary goods/services
- ***Practice Tips (per USPTO Handout)***
 - ***An ID must specify the nature of the goods being authenticated by NFTs (or the services involving NFTs), using wording that is definite and limited to a single class***
 - ***For more info, see TMEP 904.03(i)***
 - ***Virtual goods may be specified, for example, as downloadable image files (in Class 9), or provision of online non-downloadable virtual goods (Class 41)***
 - ***In describing virtual goods, avoid the common indefinite term “accessories”***
- ***Likelihood-of-confusion refusals for real versus virtual goods are based on evidence of commercial relatedness between the real and virtual goods, along with the similarity of the marks***



Federal TM Filings – What Classes



- ***Acceptable Designations (per USPTO Handout)***
 - ***Downloadable image files containing training cards authenticated by NFTs in Class 9***
 - ***Digital Collectibles in the nature of downloadable multimedia files containing artwork... authenticated by NFTs in Class 9***
 - ***Downloadable virtual goods in the nature of sunglasses, jewelry, and handbags for use in online virtual worlds in Class 9***
 - ***Sneakers authenticated by NFTs in Class 25***
 - ***Provisions of an online marketplace for buyers and sellers of digital art images authenticated by NFTs in Class 35***
 - ***Online retail store services rendered in a virtual environment featuring virtual goods, namely furniture for use in online virtual worlds in Class 35***
 - ***Entertainment services, namely, providing online, non-downloadable virtual boats and airplanes for use in virtual environments created for entertainment purposes in Class 41***
 - ***Computer programming of virtual goods for use in virtual worlds in Class 42***



TM Filing



- RTFKT Inc. Reg. No. 6837957 – Registered 6 SEP 22
- Class 009 - Downloadable virtual goods....authenticated by non-fungible tokens (nfts)
- Specimen was a website printout of the good

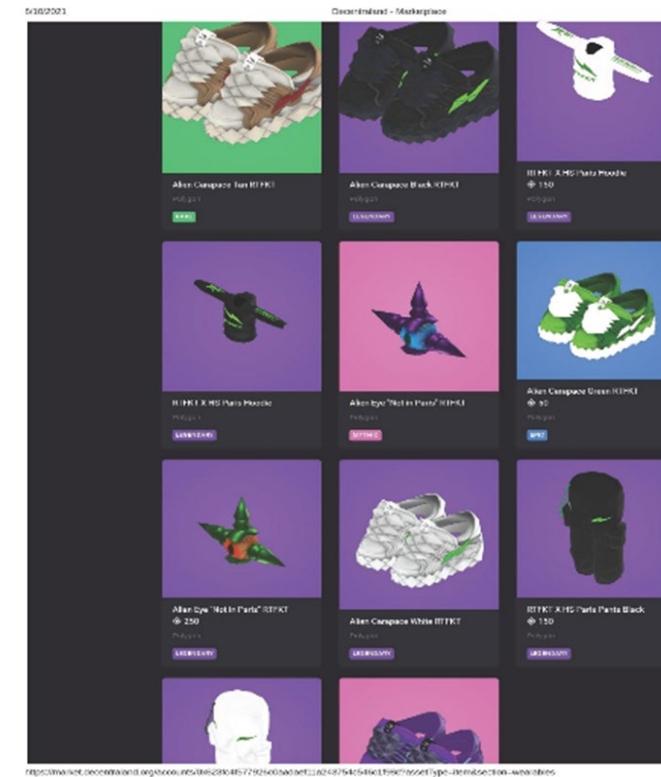



TM Filing



- Bored Ape
- 009 Digital collectibles in the nature of downloadable multimedia file containing digitally-created artwork authenticated by non-fungible tokens (nfts); digital collectibles in the nature of downloadable image files containing artwork, memes, pictures, and trading cards authenticated by non-fungible tokens (nfts)
- 035 Maintaining and recording ownership of art prints comprised of digital illustrations originating from photographs; ... online marketplace for buyers and sellers of downloadable digital collectibles in the nature of artwork, memes, trading cards, pictures, movie clips, music videos, interviews, books, newsletters, magazines, music, podcasts, and soundbites authenticated by non-fungible tokens (nfts)
- 042 Computer services, namely, creating an online community for registered users to access a collaborative graffiti board
- 045 Online social networking services provided through a members-only website

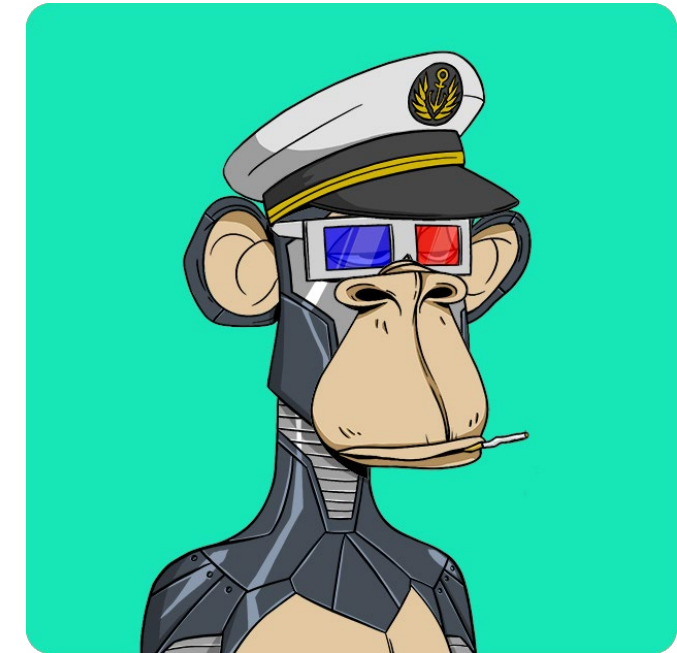



IP Considerations – Copyright

- With tangible goods
 - Is it a useful article?
 - A "useful article" is an article having an intrinsic utilitarian function that is not merely to portray the appearance of the article or to convey information. An article that is normally a part of a useful article is considered a "useful article".
 - If so -- Is it separable?
 - Pictorial, graphic, and sculptural works include the design of a useful article...shall be considered a pictorial, graphic, or sculptural work only if, and only to the extent that, such design incorporates pictorial, graphic, or sculptural features that can be separately imaginable from utilitarian aspects of the article.
- With digital goods??
- Does it matter which is designed first?
- Originality
- Derivative works: based in whole or in part on underlying work.





IP Considerations – Copyright Defenses



- Independent derivation
- Fair Use
- Parody and First Amendment
- Scenes-a-Faire/merger doctrine
- De minimis use
- Architectural works – public place exclusion



UK/EU IP Considerations



Trademark Case

- *Codemasters v Automobile Club de l'Ouest* – a contract case about a F1 racing game. Codemasters had a licence from the F1 organisers, but **not** from individual car makers, e.g. Ferrari, Porsche (which had an exclusive licence with a rival). Question was: did ACO indemnify Codemasters?





How to treat Digital Goods?



Are they:

- Products /articles?
 - **similar** to their analogue equivalents? nature, channels, consumers, price?
 - **dissimilar** to their analogue equivalents?
- Not products/articles in their own right?
 - But the **appearance** of products/articles, e.g. screen, computer program?
 - In which case, how to treat similarity?

Is their function/utility:

- Defined by their own uses? Or
- Defined by the physical goods they emulate?



Where is IP Law Currently?



Copyright

- Not sensitive to goods, worlds or dimensions.
 - **Subsistence:** “fixed in some material form” – Berne Art 1(2)
 - **Infringement:** “reproduction ... in any manner or form” – Berne Art 9(1)

Trade Marks

- Partially sensitive to goods.
 - **Subsistence:** can be 2D or 3D or virtual – “The nature of the goods ... shall in no case form an obstacle ... ” – TRIPS Art 15(4)
 - **Infringement:** “goods ... which are identical or similar” – TRIPS Art 15(1), and, for well-known marks with damage, “dissimilar” – TRIPS Art 15(3)



Where is Design Law?



- Much less harmonised than copyright or trade mark law
- **Subsistence:** Protection for “industrial designs” – TRIPS Art 25(1)
 - EU: The “appearance” of a “product” – CDR Art 3(a)
 - “Product” includes “graphic symbol”, “typeface” – 2D products with no 3D substrate
 - US: The “ornamental design” of an “article of manufacture” – 35 USC 171(a)
 - Can include (i) moving water fountain (*Re Hruby*), (ii) movable icon (*WePay v PNC*)
 - 2020 PTO PTO–C–2020–0068 consultation on whether it should include digital articles
- **Infringement:** “... articles bearing or embodying a design which is a copy” – TRIPS Art 26(1)



Designs – EU/UK Current Position



- Virtual Designs currently treated as registrable in EU, UK
- “Design” = “appearance of the whole or a part of a product” – CDR Art 3(a), Dir Art 1(a)
- “Product” = any industrial or handicraft article” CDR Art 3(b), Dir Art 1(b)
 - Including “typographical typefaces”, “graphic symbols”
 - Excluding “programs for a computer”
- Novelty = same design not disclosed (**no mention of product**)
- Ind Char = similar design not disclosed (**account taken of product**)



Compare with US position on “articles”



- *“current jurisprudence has not addressed whether a digital design not applied to or embodied in a **physical** article is eligible for design patent protection” – USPTO, 2020*
- Supreme Court in *Apple v Samsung* say an “article of manufacture” is “simply a **thing made by hand or machine.**”



Example 3D virtual product – Sgt Stripes



- RCD 000070594-0001, 29 August 2003 (“Cartoon Characters”, Cl 99.00)

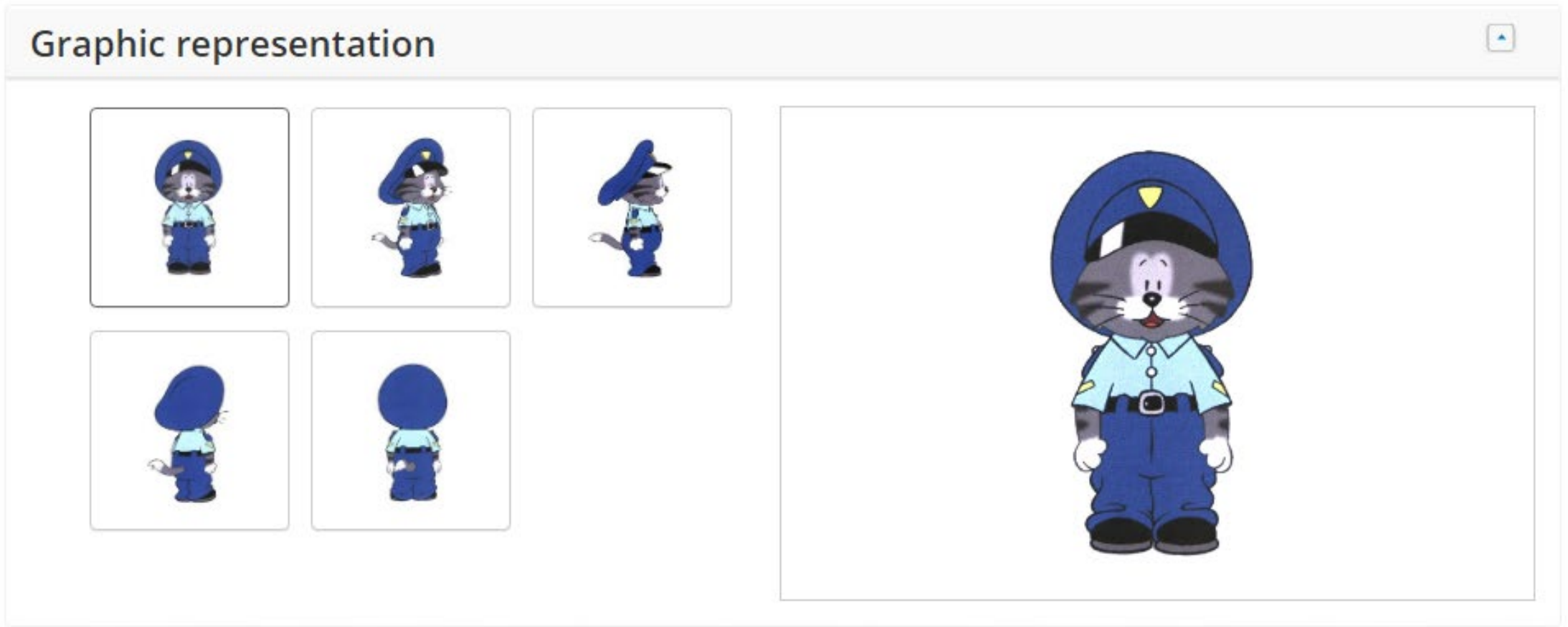



Example 3D virtual product

– “Eva Cash”,

D.i.R.T.: Origin of the Species



- RCD 000156807-0001, 16 March 2004 (“Video game characters”, Cl 21.01)

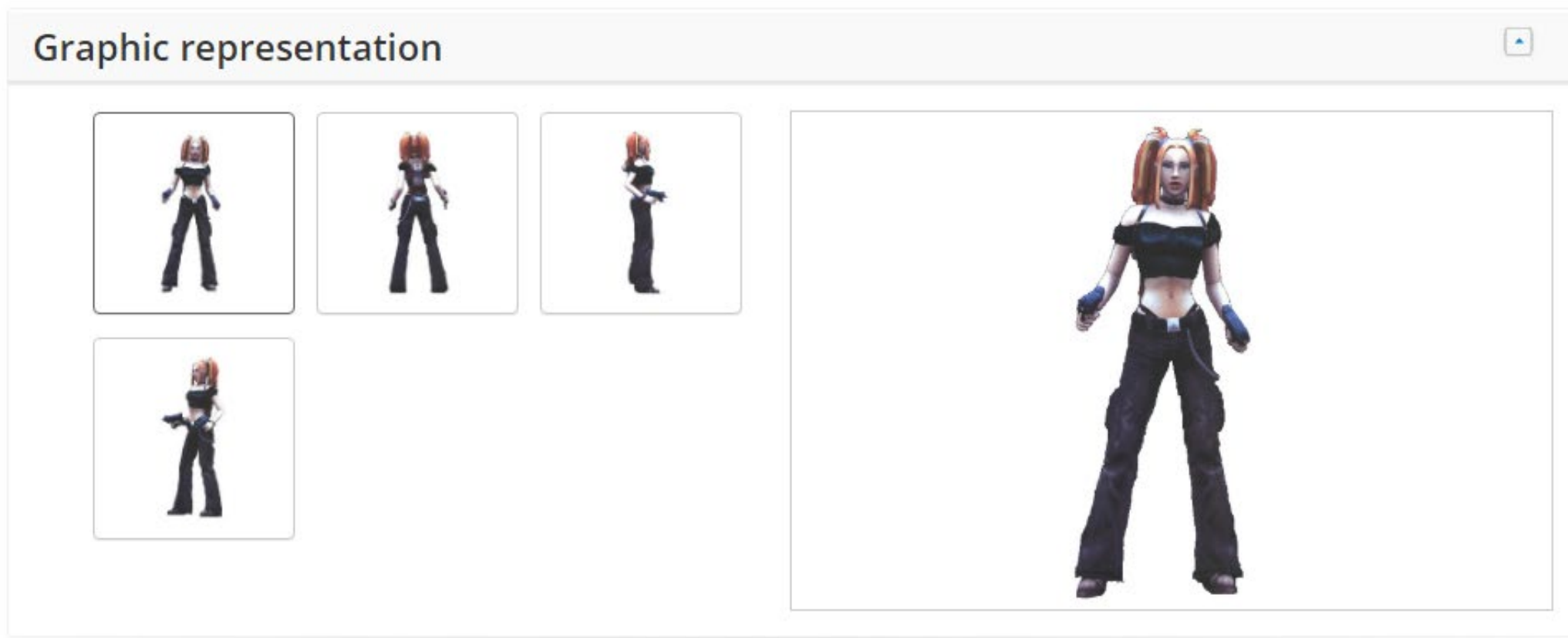



Example 3D virtual product – 3D Flowers



- RCD 009205073-0002, 13 October 2022 (“3D flowers for use in virtual environments”, Cl 14.04)





Where are they classified?



1. As graphics Class 32.01 (or, previously, 99.00)
2. As screen displays Class 14.04
3. As games Class 21.01
4. As tangible products (anywhere else)



EU Design Infringement



- *The scope of the protection ...shall include any **design** which does not produce on the informed user a different overall impression.* CDR Art 10(1), Dir Art 9(1)
- *The registration of a **design** shall confer on its holder the exclusive right to use it ...**in particular**, the making ...or using of a **product** in which the design is incorporated or to which it is applied.* CDR Art 19(1), Dir Art 12(1)
- No tie to a **particular** product: C-361/15 *Easy Sanitary Solutions*
- So: “product” such as graphic symbol is an infringement. Perhaps even infringement with no “product” at all?



Does using, trading digital goods infringe?



- Not aware of EU, UK design case law
- But there is case law on 2D depictions of 3D designs – assumed to infringe in France and Germany (see I ZR 56/09 – *ICE*), and assumption shared by CJEU (*Nintendo*, C-24/16 & C-25/16)
- Would commercially making, uploading, selling, a digital file containing 3D printer data infringe?



2022 Commission Design Law Proposals



- “‘product’ means any industrial or handicraft item other than computer programs, **regardless of whether it is embodied in a physical object or materialises in a digital form**” CDR Art 3(b), Dir Art 2(4)
- “The following, in particular, may be prohibited ... creating, downloading, copying and sharing or distributing to others any medium or software recording the design for the purpose of enabling a product ... to be made” CDR Art 19(1)(d), Dir Art 16(2)(d)
- **Intent?** This proposal aims to align the RCD protection system in the EU with the digital age ... This would facilitate in particular the filing of **new digital design types**.



Status of the Proposals? Parliament



- **ECOSOC:** Report 22 March 2023: 1.3 *“The EESC considers it essential to adapt the legal framework for designs to the digital age in order to foster the EU's recovery and resilience and encourage innovation and competitiveness. It endorses the new definition of a design set out in the proposal for a directive; it makes it more relevant in the light of technological advances, **by expanding the concept of a product to cover technological designs that are not embodied in physical objects.**”*
- **Parliament:** Patrick Breyer (Pirate Party) wants to revert the definition changes. But the Draft JURI Report does not agree.



Status of the Proposals? Council



Press release 25 September 2023

- *The Council has today adopted its positions ('general approaches') on the proposed revision of the designs legislation package: the directive on the legal protection of designs and the regulation on community designs. Updating the 20-year-old designs legislation, the new texts aim at facilitating the protection of industrial designs and adapting EU law in this area to the challenges of a digital and 3D-printing worlds.*
- *The Council supports the main objectives of the package (i.e. it keeps the concept of the 'repair clause' as proposed by the Commission), but introduces several improvements including:*
- *an update of the definition of 'design' and 'product' to make them fit for the digital age and for future technological developments. For instance, **'digital' is replaced by 'non-physical'***



Status of the Proposals? Effects if passed?



- Will affect not just EUIPO but National EU design systems
- EUIPO likely to permit use of digital files for 3D products
- Likely to expand standard descriptions of products (“EuroLocarno”)
- Probably going into Class 32
- Expect new Guidelines
- Will UK follow suit?
 - IPO was consulting on this
 - Labour committed to staying generally in step
 - Conservatives – who knows? So may have to await next election.



EU Trademarks



- Practice Tip 23 June 2022 on *Virtual goods, non-fungible tokens and the metaverse*
- “Virtual Goods” treated as digital content => into Nice, 12th Ed Class 9
 - (e.g. *downloadable virtual goods, namely, virtual clothing*)
- NFTs = certificates distinct from virtual goods they authenticate
- “non fungible tokens” on its own is not acceptable. The type of digital item authenticated by the NFT must be specified.
 - (e.g. *downloadable virtual goods, namely, virtual clothing, authenticated by non-fungible tokens*)



EU Trademarks Example

Spongebob Squarepants™



- **EU 018717501**
- **9** Downloadable multimedia files containing artwork, text, audio, and video relating to the field of entertainment authenticated by non-fungible tokens (NFTs); downloadable virtual goods, namely, software for managing crypto-collectibles and non-fungible tokens (NFTs); downloadable computer software for managing crypto-collectibles and non-fungible tokens (NFTs).
- **35** Providing an online marketplace for buyers and sellers of crypto collectibles; providing an online marketplace for buyers and sellers of blockchain-based non-fungible assets; operating on-line marketplaces featuring crypto collectibles and blockchain-based non-fungible assets; providing an online marketplace for buyers and sellers of downloadable digital art images authenticated by non-fungible tokens (NFTs); providing an online marketplace for buyers and sellers of downloadable digital artwork relating to the field of entertainment authenticated by non-fungible tokens (NFTs); providing an online marketplace for buyers and sellers of non-fungible tokens (NFTs) and other digital tokens based on blockchain technology; providing an online marketplace for buyers and sellers of non-fungible tokens (NFTs) and other digital tokens based on blockchain technology that incorporate digital collectibles and digital art; providing a website featuring consumer product information about downloadable digital art images; providing a website featuring consumer product information about crypto collectibles and blockchain-based non-fungible assets.
- **42** Software as a service (SAAs), namely, software for transferring crypto-collectibles and application tokens; platform as a service (PAAs), namely, software for accessing crypto-collectibles and application.



EU Trademarks



- *PAN 2/23 NFTs, virtual goods, and services in the metaverse* “Unlike their physical counterparts, virtual goods are classified in class 9 of the Nice Classification system.”
- **Virtual goods in Class 99, with or without NFTs**
 - E.g. *digital art authenticated by non-fungible tokens [NFTs]*
- **Physical products with NFTs in the relevant product class.** E.g.
 - Handbags, authenticated by non-fungible tokens [NFTs] [Class 18]
 - Training shoes, authenticated by non-fungible tokens [NFTs] [Class 25]
- **Virtual Services**
 - In same class as physical counterparts, e.g. class 35 for virtual malls (see PAN 1/15)
 - Or generally, *entertainment services, namely, provision of a virtual reality or metaverse based simulation gaming service*



How many EU marks out there?



- Search for Trade marks with *Nice Classification* like "9" and *Goods and services* like "non fungible tokens", **2559** hits
- Search for Trade marks with *Nice Classification* like "9" and *Goods and services* like "nft", **4048** hits
- Search for Trade marks with *Goods and services* like "metaverse", **939** hits
- Many of these are pending – may be quite a backlog.



Status of 2D or 3D virtual goods as a TM



- Wide use of 2D images as onscreen trade marks
- What about 3D virtual goods? Likely to encounter scepticism that the goods are functioning as a mark. So evidence of use (in all EU States) may be necessary.
- Specific exceptions?
 - “Nature of the goods” – can’t see how that would apply
 - “Characteristic that adds value” – might be applicable. But C-237/19 *Gömböc* shows that other causes of value (e.g. the story of its creation, its method of production, ... or even the identity of its designer) may be in play. So – what is adding the value of a virtual good? Rarity? Use in game play?? Fact-dependent – no default position.
 - Technical function? Considered later.



Infringement across categories?



- Seems clear that clothing (Cl 25) is not identical to virtual clothing (Cl 9)
- Should a clothing mark block a later mark for virtual clothing?
 - Seems fairly obvious that it should. But, per contra, *C-48/05 Adam Opel*
 - And vice versa? Should all searches now cross-search Class 9 for virtual equivalents?
- So are these always “similar goods” for infringement purposes? Is there a “likelihood of association”?
- Or are they as different as cars and replicas: different origins, virtual use causing no damage to the “essential function” of the mark for goods?
- Are all virtual goods in Class 9 “similar goods” to each other no matter how dissimilar the physical equivalents are?



EU Copyright – an “Open-list” system



- Clear from CJEU that any work of the mind can be protected if:
 - Original (“author’s own intellectual creation”),
 - Expression not idea, and
 - Clearly characterizable.
 - See e.g. C-683/17 *Cofemel*, C-833/18 *Brompton Bicycle*
- On-screen displays protectable as artistic works: C-393/09 *BSA*
- Video games: “*complex matter comprising not only a computer program but also graphic and sound elements, which, although encrypted in computer language, have a unique creative value which cannot be reduced to that encryption. In so far as the parts of a videogame, in this case, the graphic and sound elements, are part of its originality, they are protected, together with the entire work, by copyright ...*” C-355/12 *Nintendo v PC Box*



UK Copyright – still a “Closed-list” system

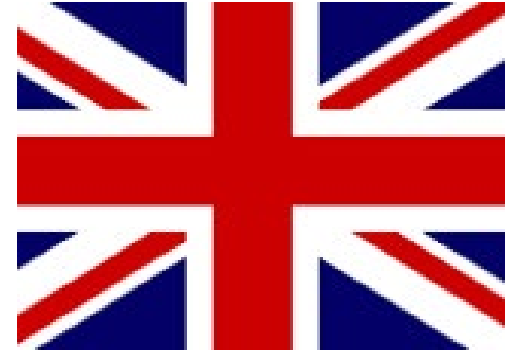

- 2D images are “graphic works”. But *“Graphic work” is defined as including all the types of thing specified in s.4(2) which all have this in common, namely that they are static, non-moving*. Jacob LJ, *Nova v Mazooma*
- 3D virtual objects might be protected by copyright in their “design documents” if those are “graphic works” – less clear if they are classed as “literary works”.
- Does s.51 CDPA 1988 kick in? *“It is not an infringement of any copyright in a design document or model recording or embodying a design for anything other than an artistic work or a typeface to make an **article** to the design or to copy an article made to the design”*.
- But is a virtual thing an “article”? Undefined in the CDPA. Must in context be something capable of having a “shape and configuration”. But *“[th]ere is no reason why a “design” should not subsist in what people would ordinarily call a “flat” or “2-dimensional” thing”* – Jacob LJ, *Lambretta Clothing v Teddy Smith*.



3D goods: UK “Sculpture” or “WAC”?

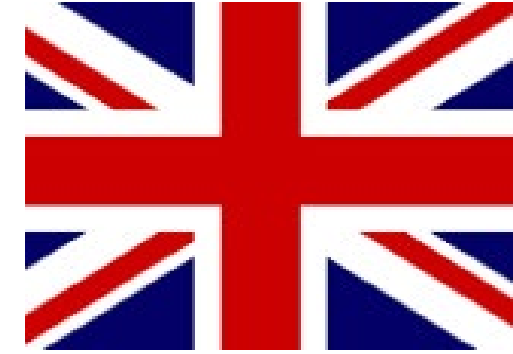

Both these categories in the UK seem to require some artistic purpose – being functional/utilitarian isn't enough. *Lucasfilm v Ainsworth*.

But what functions do games/metaverse digital goods have?

- “Function” of being played with, encouraging imagination? (compare *Lucasfilm* first instance in the UK with *Gay Toys v Buddy* in the US)
- “Function” of conveying the character? (*Lucasfilm* at first instance)
- Same function as real article? E.g. virtual car would be utilitarian/functional. *Lucasfilm CA: Mr Bloch seeks to avoid our example of a real soldier's helmet being used as a prop in a film by stressing the fictional and imaginary nature of the stormtroopers and what they were. These were not, he submits, the helmet and armour of a real soldier and are therefore no more part of reality than the horn of a unicorn would be. That is not a real horn and this is not, in any real sense, a helmet. But that argument confuses the fictional nature of the stormtrooper with his physical depiction in the film. **Although invented, the helmet and armour are still recognisable as such and have a function within the confines of the film as the equipment of the stormtrooper.** They are, to that extent, no different from and serve the same purpose as any real helmet or armour used in a film”*



Design & Trade Mark Functionality



- Do similar arguments apply in design and trade mark law?
- Do you:
 - A. Conclude that all virtual goods are essentially functionless “content”, not part of the GUI or computer which would define their function?
 - B. Conclude that functionality is dictated by the rules of the virtual world in which they exist (which are usually less restrictive than reality)? E.g. ability to recover from crashes, injuries, etc?
 - C. Treat them just like their real-world analogues?



CN IP Considerations



IP Considerations – Design Rights



- Partial designs are newly available in CN
 - If such digital goods are part of the graphical user interface, a partial GUI design may be an approach to protect such digital goods
- At least the Shanghai court has ruled that GUI designs are protectible, regardless of the differences of the hardware products (such as mobile phone or monitor), which embody such GUI
- Design registrations (at least some) are being registered for digital products



Design Registrations

- *CN 308101645; 308101644; 308096042; and 308096041*
 - – *Assignee: Lantu Automobile Technology Co Ltd,*
- Virtual character graphical user interface used to display screen panels (used for vehicle central control)

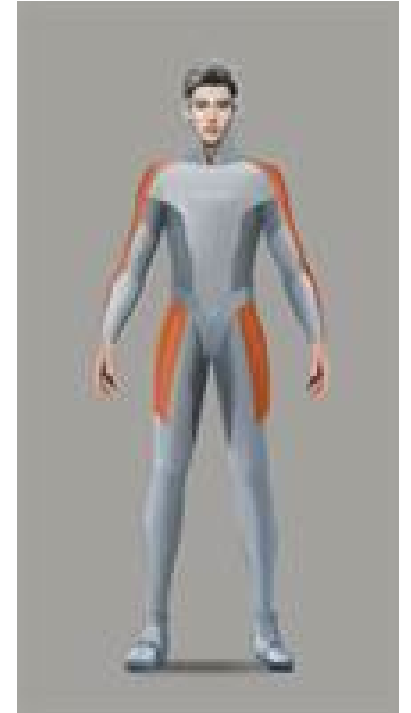
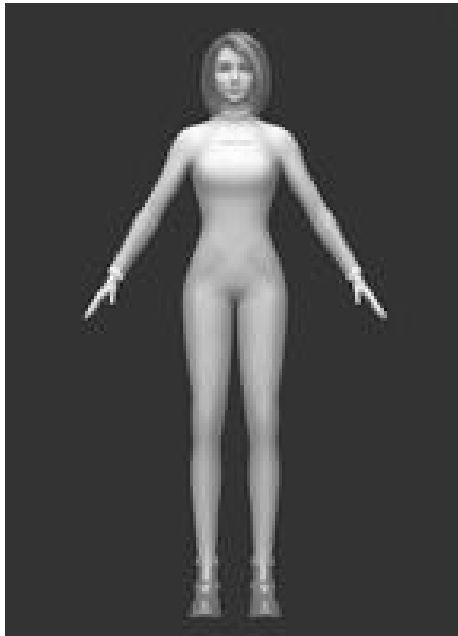



Design Registration

- *CN 307427326 – Assignee Beijing Shiyue Xingcheng Technology Co.*
- Virtual Sneakers





Design Registration



- *CN 308226646 – Assignee Yukuai Chuangling Intelligent Technology (Nanjing) Co Ltd*
- Graphical user interface for virtual display of screen panels





Design Registration

- *CN 308191422 – Assignee SHANXI JINBO BIO-PHARMACEUTICAL Co Ltd*
- *Model decoration (Jinbo Biological Digital Human Perfect)*
- *The purpose of this design product is to create cartoon character model decorations for viewing and display.*

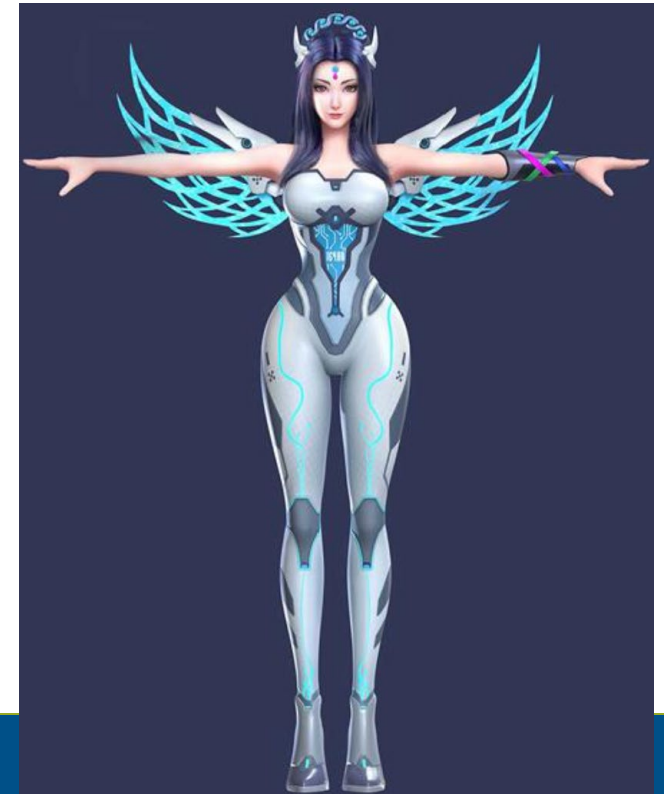



IP Considerations – Trademarks



- The challenges are whether the use of trademark on digital goods in digital environment is considered the use on “identical or similar goods”.
- Possible solutions:
 - Well-known trademark: the use of a trademark in digital environment, e.g, virtual stores or gaming, may be considered as the use in "Group 0901 Virtual Reality Game Software; Group 4105 Virtual Reality Arcade Services, Virtual Reality Games“. A well-known trademark owner may rely on its registration to seek protection on such “dissimilar goods or services”.
 - Well-known trademark owner may also seek protection against “diluting or derogatory effect”
 - Anti-unfair Competition Law: it has general clause against “misleading behavior sufficient to mislead people into believing that they are others' goods or have a specific connection with others“
- No cases found yet on trademark infringement on digital goods



IP Considerations – Copyright



- China has generally provided protection for game characters and copyrighted works in the context of NFT, mostly through the “artistic works”.
- The concept of artistic works refers to aesthetically significant two-dimensional or three-dimensional artistic works, such as paintings, sculptures, calligraphy, and other forms, created through lines, colors, or other means.
- The infringed rights are the right of dissemination via information networks - the right to provide works that may be obtained by the public at the time and place selected by the public by wired or wireless means.



Copyright Case



- In the case filed by Netease, in 2021, the Guangzhou Court ruled that the in-game characters of "Fantasy Westward Journey" are regarded as artistic works.
- The defendant's use of similar character images and game props constitutes infringement on the "right of information network dissemination" and unfair competition.
- Pending for retrial



Copyright Case



- Popular animated character “I’m not Fat Tiger” created by cartoonist Ma Qianli (licensed by Qice) -- heavily licensed.
- Qianli created a “Fat Tiger in Vaccination” for a book entitled “Tiger Down the Mountain”
- Defendant operated a "Meta Universe" platform where it “minted” artwork into NFTs, and took fees (10% of first sale, 2ndary 10% of increases, & minting fees)
- Defendant minted and let unauthorized NFTs for “Fat Tiger Vaccination” (899 yuan) be sold on its "Meta Universe" platform.

www.taylorwessing.com/-/media/taylor-wessing/files/germany/2022/06/mv-nl_04-2022_first-nft-decision-in-china_urteil--internet-court-hangzhou_final_neu_pdfa.pdf

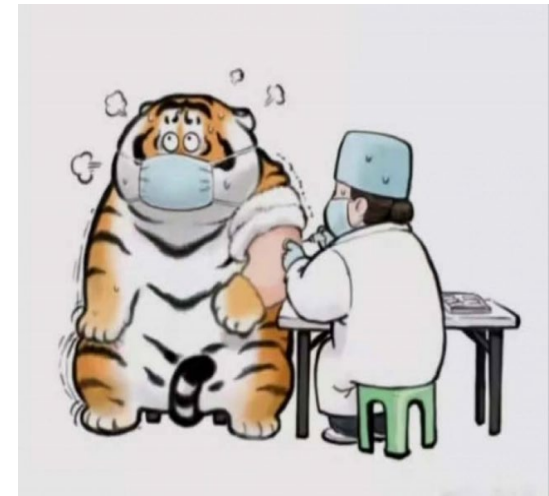



Copyright Case

21st Open Forum
London, England
4-7 October 2023



- The NFT digital artistic work trading service platform was found liable for aiding infringement.
 - It failed to fulfill its obligation of review. Court took into account factors such as the transactional level, technical characteristics, platform control ability, and profit model of the platform
 - Noted the platform should also establish an effective intellectual property review mechanism to do preliminary examinations of the copyright of NFT works traded on the platform, such as examining whether the user applying for NFT minting has provided preliminary evidence involving copyright manuscripts, originals, legal publications, copyright registration
- The “Fat Tiger in Vaccination” was a work of art
- Qice was the exclusive licensee and authorized to bring suit
- Court ordered the defendant to delete the infringing NFT artworks and compensate the plaintiff with 4,000 yuan (\$550 USD)(asked for 25x that).



IP Takeaways - Everywhere

21st Open Forum
London, England
4-7 October 2023



- Creators who create tangible products who do not want their design misappropriated in digital form need to pay attention to these issues
- Creators who create digital products who do not want their designs misappropriated in either or both digital or physical forms need to pay attention to these issues
- Consider using a holistic strategy with all IP forms
- Consider within a fiscal strategy



IP Takeaways



- Procure them all if possible
- Design Patents
 - Very tricky – be on cutting edge
- Trademarks
 - Create and sell (i.e., use) goods
 - Register mark – use acceptable identifications and classes
- Copyrights
 - Register work
 - Think how you want to present the application
- Effectiveness will be fact driven



IP Takeaways



- **Brand owners: trade in virtual worlds:**
 - If you allow separate channels to develop, your rights may not travel between worlds
 - You will get cybersquatters who damage your reputation
- **And file for virtual goods**
 - No intention-to-use test at EUIPO
 - But UK filing with no ITU lays you open to bad-faith cancellation
- **Register your designs**
 - We don't know where EU and UK copyright will come out on this yet
 - Design registration is currently easy and will probably be easier soon



IP Takeaways



- When trademark law remedies are difficult, always remember China has a powerful anti-unfair competition system, dealing with counterfeits and infringement
- China has a strong pro-copyright environment. Registration is not necessary, but it is worth registering for the sake of ease of enforcement
- Maybe, designers in metaverse environment should work harder to file GUI design patents in China to capture their unique designs



21st Open Forum
London, England
4-7 October 2023





FICPI ExCo & 21st Open Forum

London, 1-7 October 2023



STRENGTHENING THE PRACTICE OF THE INDEPENDENT IP ATTORNEY

www.ficpi.org